

# AirHeat Burners

## Model AH version 2.00

(Patent Pending)

### Main Specifications

PARAMETER	SPECIFICATIONS	
	English	Metric
Maximum input: at neutral conditions and $\Delta P \text{ Air}^1) = 1.0''\text{w.c. (2.5mbar)}$	1,000,000 Btu/hr/LF	961 kW/m
Minimum input: at neutral conditions and $\Delta P \text{ Air}^1) = 1.0''\text{w.c. (2.5mbar)}$	25,000 Btu/hr/LF	24.5 kW/m
Main gas inlet pressure • natural gas pressure at gas inlet (Tap "B")	10 "w.c.	25 mbar
High fire flame length <sup>2)</sup> • measured from the burner outlet.	43 in	1100 mm
Temperature limit	Packaged blower <sup>3)</sup> Remote Blower	-40 to +104 °F -40 to +40 °C -40 to +750 °F -40 to +400 °C
Downstream temperature limit	1500 °F	815 °C
Flame monitoring	Flame rod or UV scanner	
Ignition	Direct spark ignition Spark ignited pilot <sup>4)</sup>	
Fuel	Natural Gas, Propane or Butane. <sup>5)</sup> For any other mixed gas, contact Eclipse Combustion.	

- 1)  $\Delta P \text{ Air}$  is measured between tap "A" and tap "C" (see page 5 for tap locations).
- 2) Based on typical parallel process air flow. If mounted in a cross flow, flame will be shorter.
- 3) Based on blower motor limitations.
- 4) Pilot input ~25,000 Btu/hr (7.3 kW).
- 5) See Design Guide 135 for more information about typical combustion and properties.

- All information is based on laboratory testing in neutral (0.0" w.c.) chamber. Different chamber conditions will effect the data.
- All inputs based upon gross calorific values and standard conditions: 1 atmosphere, 70 °F (21 °C).
- Blower motor service factors greater than 1.0 may be required when firing into negative chamber pressure applications. For specific application questions, contact your Eclipse Combustion representative.
- Eclipse reserves the right to change the construction and/or configuration of our products at any time without being obliged to adjust earlier supplies accordingly.



Eclipse Combustion

ISO 9001 Registered

# Performance Graphs

### Control & Operational Zone

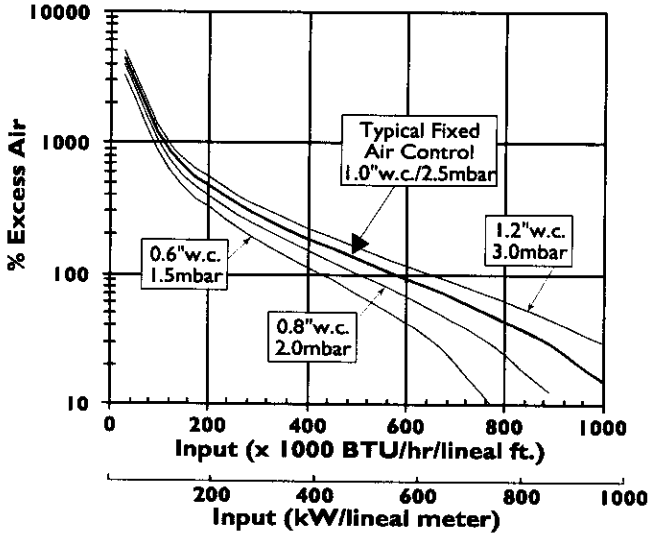

**Notes on Control & Operational Zone**  
 This graph shows the amount of excess air through the burner at various  $\Delta P$  air settings and as a function of the input. At lower excess air levels, complete combustion will require sufficient  $O_2$  in the process air flow.  
 Contact your local Eclipse Combustion representative with details of your application.

### NO<sub>x</sub> and CO Emission Data (at 3 vol. % O<sub>2</sub> - dry)

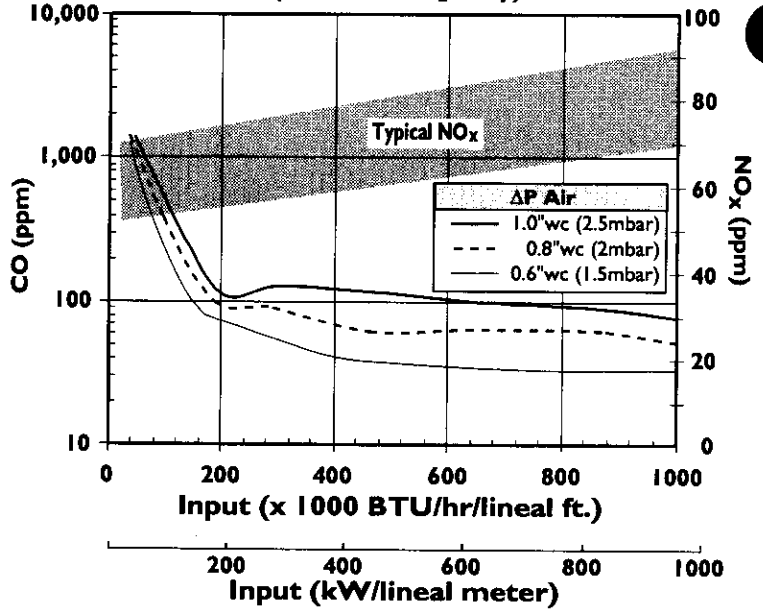

**Notes on emission data**  
 NO<sub>x</sub> and CO emission data is given for:  
 • Ambient combustion air ~70 °F (20 °C)  
 • Minimal process air velocity  
 • Neutral chamber pressure  
 • Natural Gas  
 Emissions are influenced by:  
 • Chamber conditions  
 • Fuel type  
 • Firing rate  
 • Combustion air temperature  
 CO emission is largely influenced by chamber conditions. Contact your local Eclipse Combustion representative for an estimate of CO emission on your application.

### Fuel $\Delta P$ vs. Input (Measured between Taps "B" and "C")

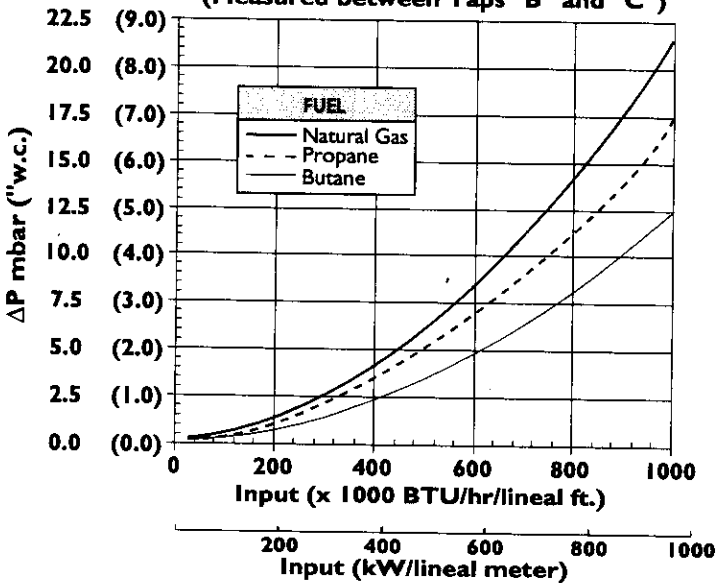

### Burner Flame Length (Measured from the Burner Outlet)

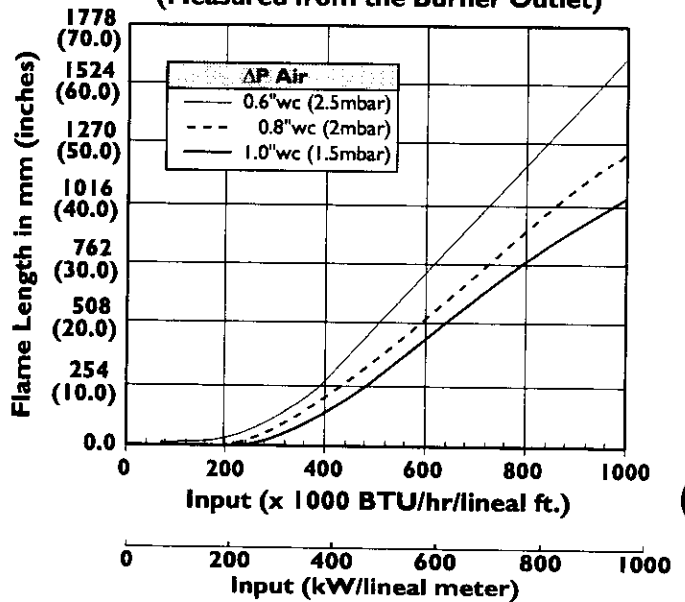

**Dimensions & Specifications in Inches**  
(See Page 4 For Metric Dimensions)

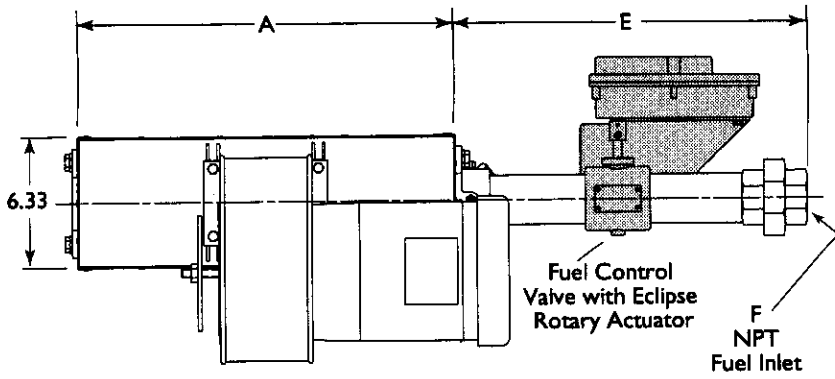

NOTE: All views indicate right hand piping.  
Left hand piping is available. See Price List 135

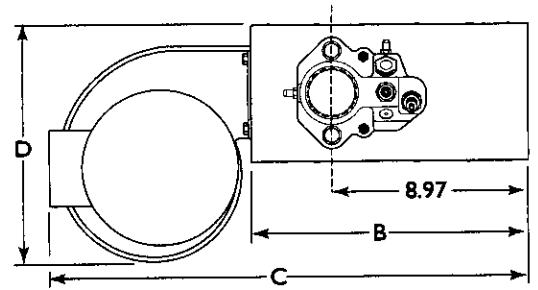

**Duct Mounting**

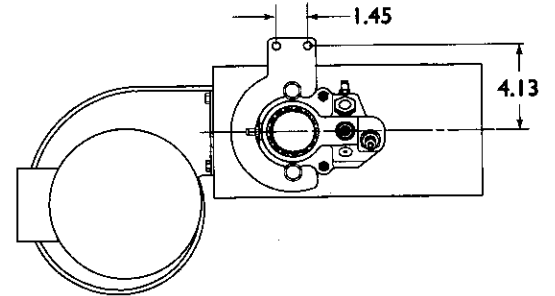
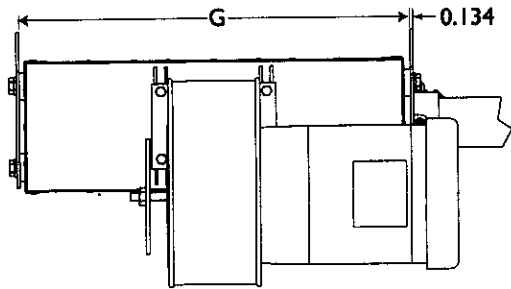

**Slot Firing**

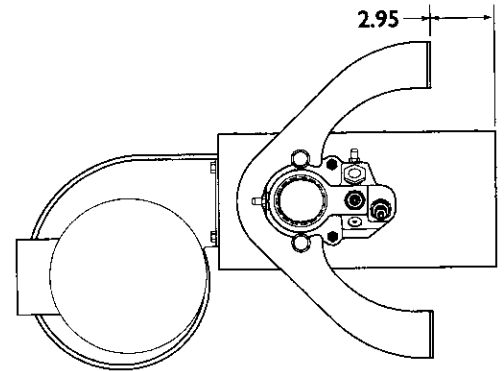
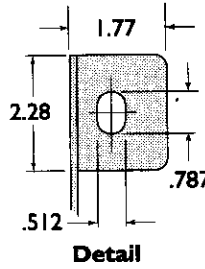
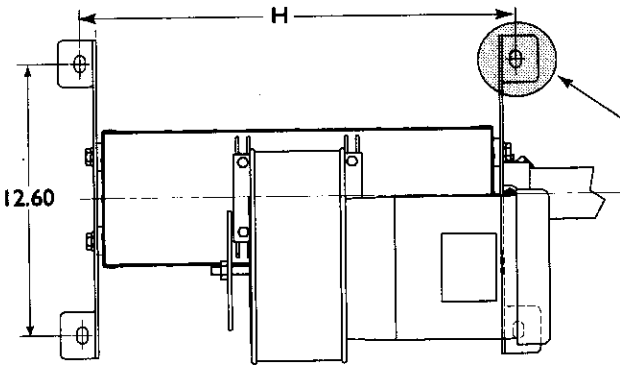

**Continuous Mounting**

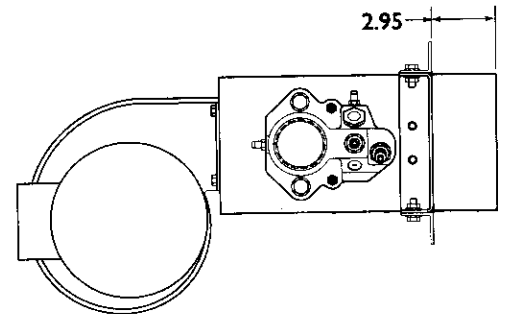
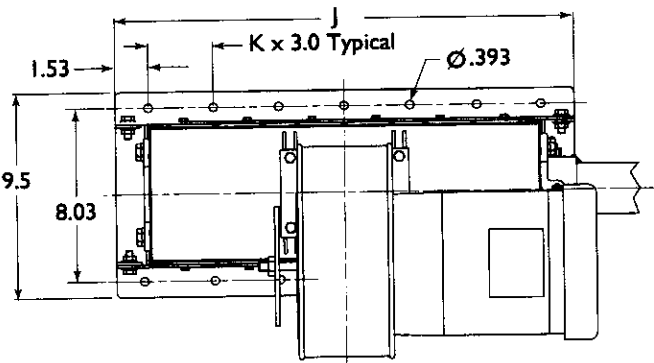

Burner Model	Max. Input Btu/hr.	A	B	C	D	E			F			G	H	J	K	Cross Sect. Area In. <sup>2</sup>	Approx. Ship. Wt. lb
						Nat. Gas	Propane	Butane	Nat. Gas	Propane	Butane						
AH0050	500,000	6.10	12.72	21.42	10.91	16.06	16.06	16.06	1	1	1	6.68	8.18	9.25	2	39	42
AH0100	1,000,000	12.01	12.72	21.42	10.91	16.65	16.06	16.06	1-1/2	1	1	12.59	14.08	15.16	4	76	49
AH0150	1,500,000	17.91	12.72	21.42	10.91	16.65	16.65	16.06	1-1/2	1-1/2	1	18.49	19.99	21.06	6	114	57
AH0200	2,000,000	23.82	12.72	23.35	14.80	16.65	16.65	16.65	1-1/2	1-1/2	1-1/2	24.40	25.89	26.97	8	151	77
AH0250	2,500,000	29.72	12.72	23.35	14.80	16.65	16.65	16.65	1-1/2	1-1/2	1-1/2	30.30	31.80	32.87	10	188	85
AH0300	3,000,000	35.63	12.72	23.35	14.80	16.73	16.65	16.65	2	1-1/2	1-1/2	36.21	37.70	38.78	12	226	92
AH0350	3,500,000	41.54	12.72	23.35	14.80	16.73	16.65	16.65	2	1-1/2	1-1/2	42.11	43.61	44.69	14	263	100
AH0400	4,000,000	47.44	12.72	23.35	14.80	16.73	16.73	16.65	2	2	1-1/2	48.02	49.52	50.59	16	301	107

## Dimensions & Specifications in mm

(See Page 3 For Inches)

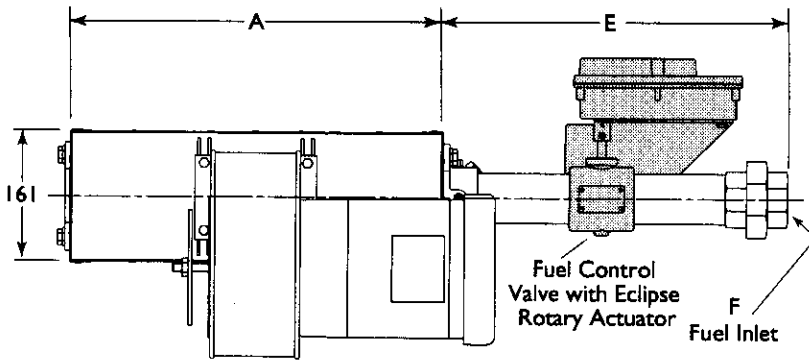

NOTE: All views indicate right hand piping.  
Left hand piping is available. See Price List 135

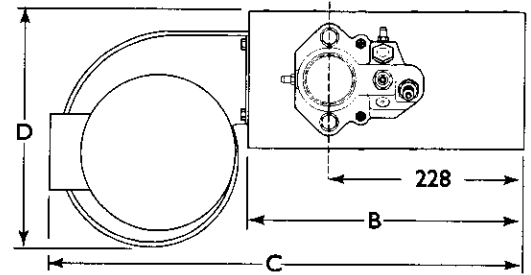

### Duct Mounting

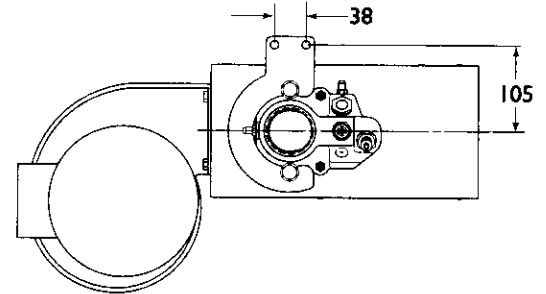
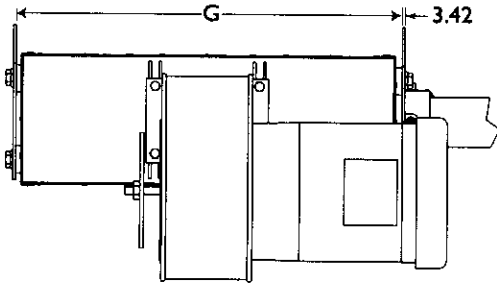

### Slot Firing

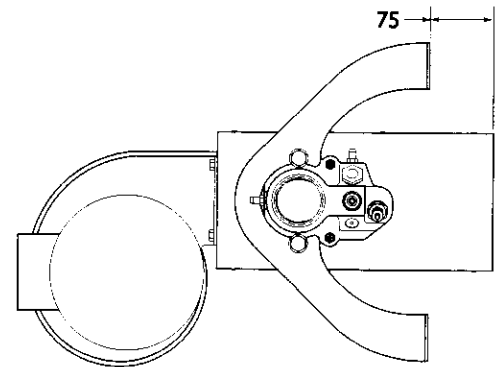
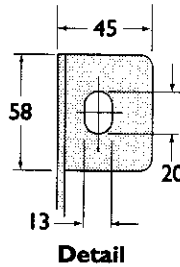
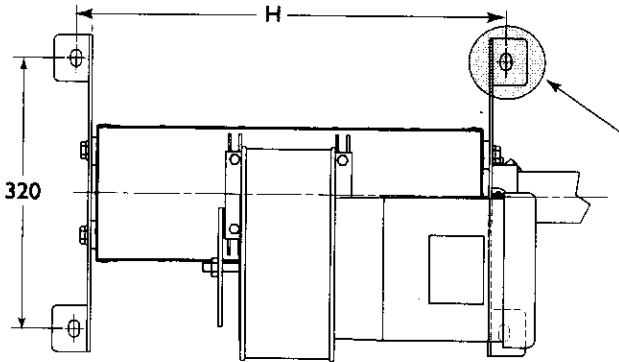

### Continuous Mounting

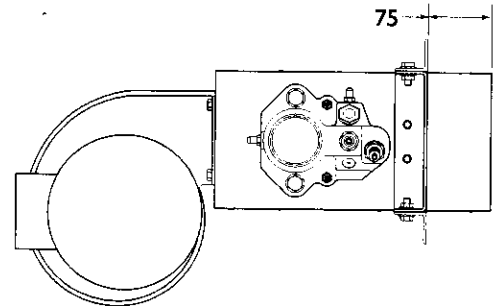
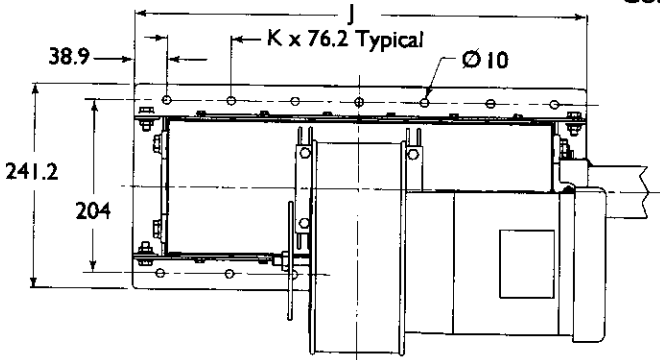

Burner Model	Max. Input kW	A	B	C	D	E			F			G	H	J	K	Cross Sect. Area cm <sup>2</sup>	Approx. Ship. Wt. kg
						Nat. Gas	Propane	Butane	Nat. Gas	Propane	Butane						
AH0050	481	155	323	544	277	408	408	408	Rc1.0	Rc1.0	Rc1.0	169.7	207.7	235	2	250	19
AH0100	961	305	323	544	277	423	408	408	Rc1.5	Rc1.0	Rc1.0	319.7	357.7	385	4	491	22
AH0150	1442	455	323	544	277	423	423	408	Rc1.5	Rc1.5	Rc1.0	469.7	507.7	535	6	733	26
AH0200	1922	605	323	593	376	423	423	423	Rc1.5	Rc1.5	Rc1.5	619.7	657.7	685	8	974	35
AH0250	2403	755	323	593	376	423	423	423	Rc1.5	Rc1.5	Rc1.5	769.7	807.7	835	10	1216	39
AH0300	2883	905	323	593	376	425	423	423	Rc2.0	Rc1.5	Rc1.5	919.7	957.7	985	12	1457	42
AH0350	3364	1055	323	593	376	425	423	423	Rc2.0	Rc1.5	Rc1.5	1069.7	1107.7	1135	14	1699	45
AH0400	3844	1205	323	593	376	425	425	423	Rc2.0	Rc2.0	Rc1.5	1219.7	1257.7	1285	16	1940	49

## Dimensions & Specifications (Cont.) End Plates

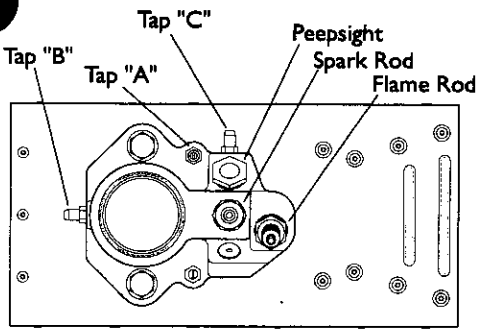

Separate Spark and Flame Rod

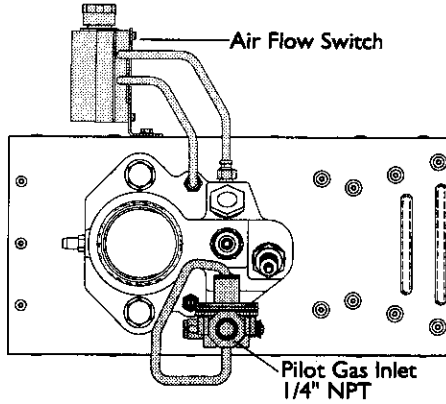

Optional Spark Ignited Pilot  
and Air Flow Switch

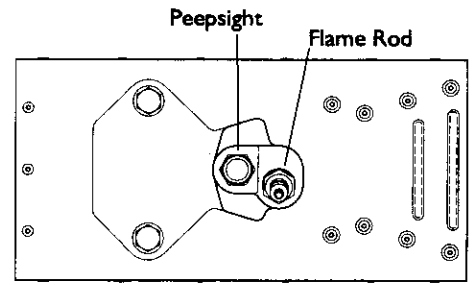

Optional Flame Monitoring  
End Plate and Flange

### Combustion Air Inlet

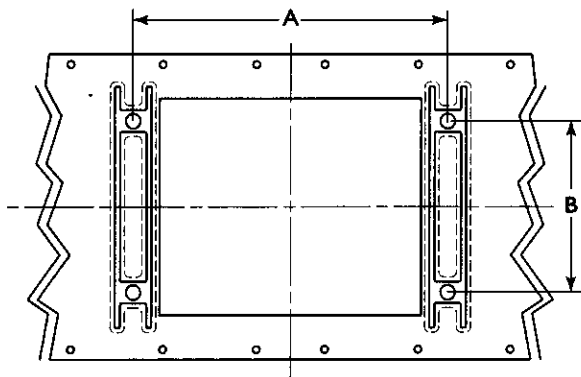

Burner Model	Dimensions			
	mm		Inches	
	A	B	A	B
AH0050	127.0	82.3	5.00	3.24
AH0100	127.0	82.3	5.00	3.24
AH0150	127.0	82.3	5.00	3.24
AH0200	185.7	101.6	7.31	4.00
AH0250	185.7	101.6	7.31	4.00
AH0300	185.7	101.6	7.31	4.00
AH0350	185.7	101.6	7.31	4.00
AH0400	185.7	101.6	7.31	4.00

### Process Flow Considerations

#### Parallel Process Flow

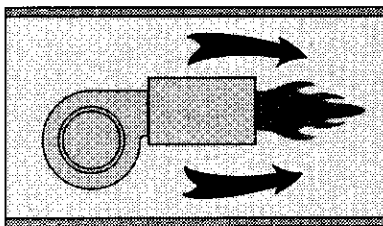

In Duct

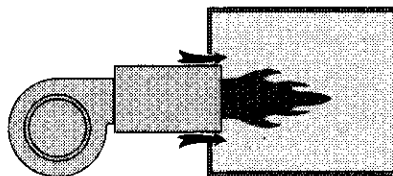

Slot - Fired

**Min./Max. Velocity:** 500 to 6000 fpm  
2.54 to 30.48 m/s

**Optimum Velocity:** 1000 to 4000 fpm  
5.08 to 20.32 m/s

#### Perpendicular Process Flow

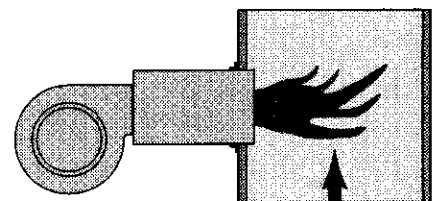

Sealed or Slot Fired

**Min./Max. Velocity:** 500 to 1200 fpm  
2.54 to 6.10 m/s



**Offered By:**

Power Equipment Company  
2011 Williamsburg Road  
Richmond, Virginia 23231  
Phone (804) 236-3800  
Fax (804) 236-3882

---

[www.peconet.com](http://www.peconet.com)